

# TELONG ENERGY TECHNOLOGY CO., LTD.

Anjia Industrial Zone, HuanGuan South Road, GuanLan Town, ShenZhen City, GuangDong Province, China  
 TEL:+86-755-29052355 FAX:+86-755-27981742 E-mail:[telongbattery@sztlg.com](mailto:telongbattery@sztlg.com) <http://www.sztlg.com>

## 120H1A Ni-MH BUTTON CELL

### TECHNICAL DATA

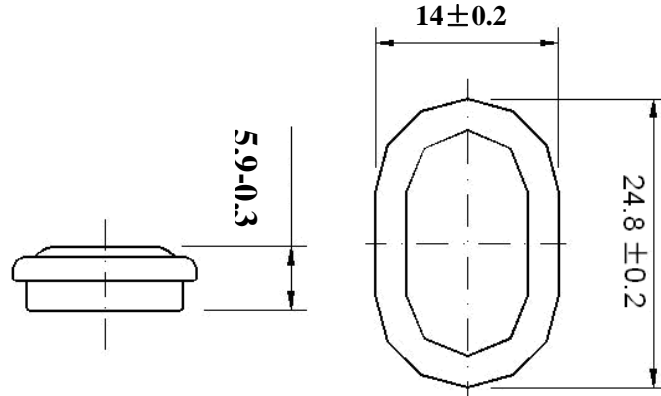

Model	Voltage	Capacity	Recommended Trickle Charge Current	Nominal Charge Current	Normal Charging Time	Nominal Discharge Current	Weight
120H1A	1.2V	120mAh	3.7~6mA	12mA	14~16h	24mA	5.1g

### TECHNICAL CHARACTERISTICS

TYPICAL CHARGE CURVE (12mA)

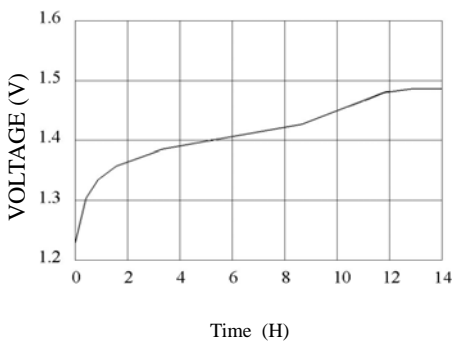

TYPICAL DISCHARGE CURVE (24mA)

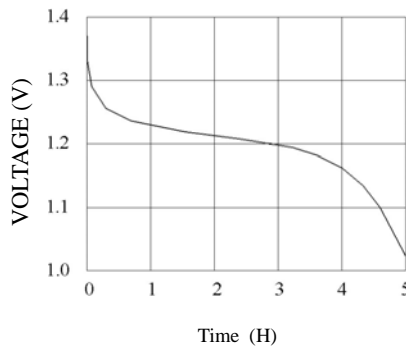

CYCLE LIFE CURVE

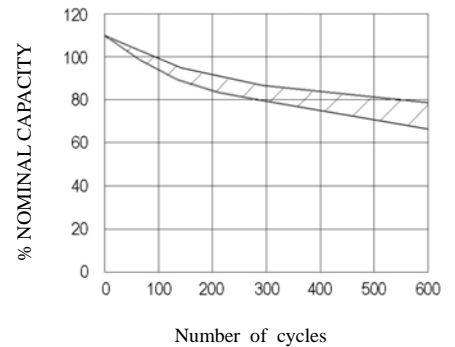

TYPICAL CHARGE CURVE AT VARIOUS CURRENTS

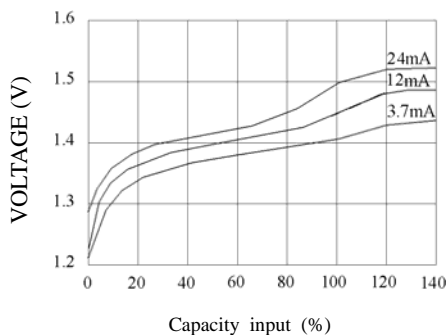

DISCHARGE CURVE AT VARIOUS TEMPERATURES (24mA)

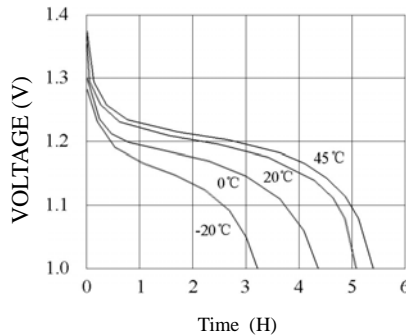

SELF DISCHARGE RATE AT VARIOUS TEMPERATURES

