

TELONG ENERGY TECHNOLOGY CO., LTD.

Anjia Industrial Zone, HuanGuan South Road, GuanLan Town, ShenZhen City, GuangDong Province, China

TEL:+86-755-29052355 FAX:+86-755-27981742 E-mail:telongbattery@sztlg.com <http://www.sztlg.com>

Lithium manganese dioxide battery

CR3032

Specifications

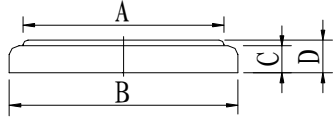
Nominal Voltage	3V	Dimensions (mm) 	A	$\phi 27.3$
Nominal Capacity	500 (mAh)		B	$\phi 30.0^{+0.0}_{-0.3}$
Continuous standard load	7.5 (K Ω)		C	2.5
Operating temperature	-20 ~ 70 $^{\circ}$ C		D	$3.2^{+0.0}_{-0.3}$
Weight	6.8g			

Discharge characteristics

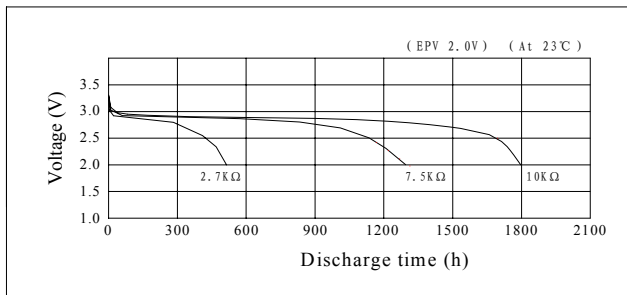

Temperature characteristics

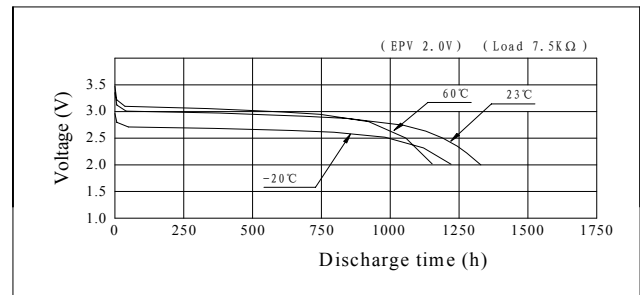

Load vs. Operating voltage

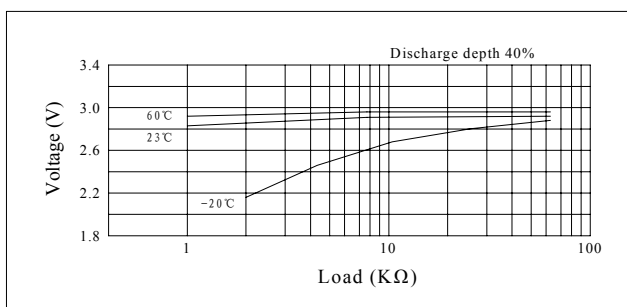

Load vs. Capacity

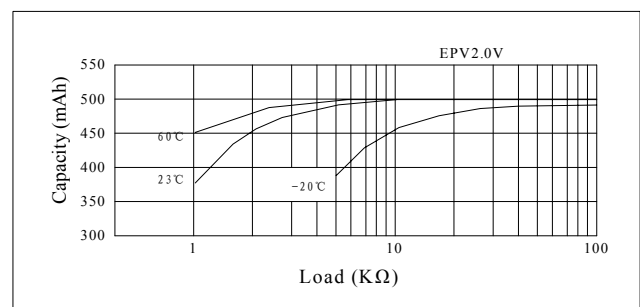

Pulse discharge characteristics

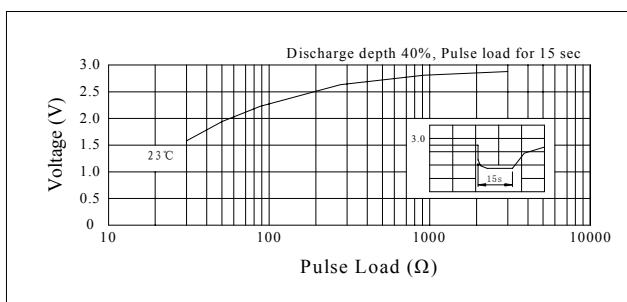

Storage characteristics

