

TELONG ENERGY TECHNOLOGY CO., LTD.

Anjia Industrial Zone, HuanGuan South Road, GuanLan Town, ShenZhen City, GuangDong Province, China

TEL:+86-755-29052355 FAX:+86-755-27981742 E-mail:telongbattery@sztlg.com <http://www.sztlg.com>

ER2450 Lithium Thionyl Chloride Battery

TECHNICAL DATA

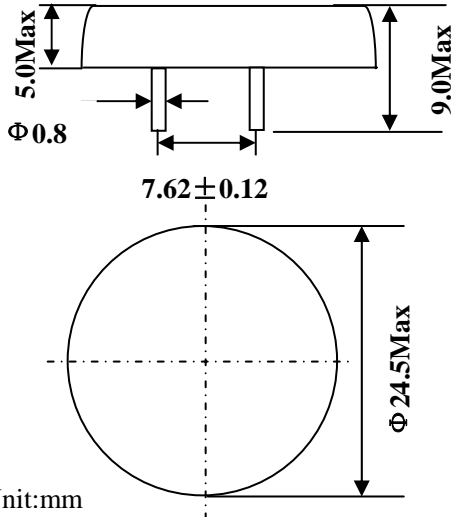

Characteristics: ($23 \pm 2^\circ\text{C}$)
 Nominal capacity (2mA-2.0V)0.5AH
 Nominal voltage3.6V
 Standard discharge current.....2mA
 Maximum continuous current.....4mA
 Maximum pulse current.....10mA
 Weight.....10g
 Volume.....24.5×5.8mm
 Operating temperature range..... $-55^\circ\text{C} \sim +85^\circ\text{C}$

TECHNICAL CHARACTERISTICS

■ Discharge characteristics at $23 \pm 2^\circ\text{C}$

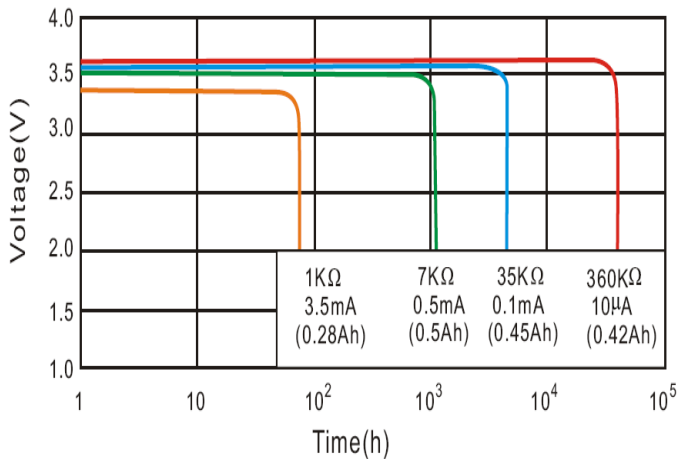

■ Capacity VS. Current

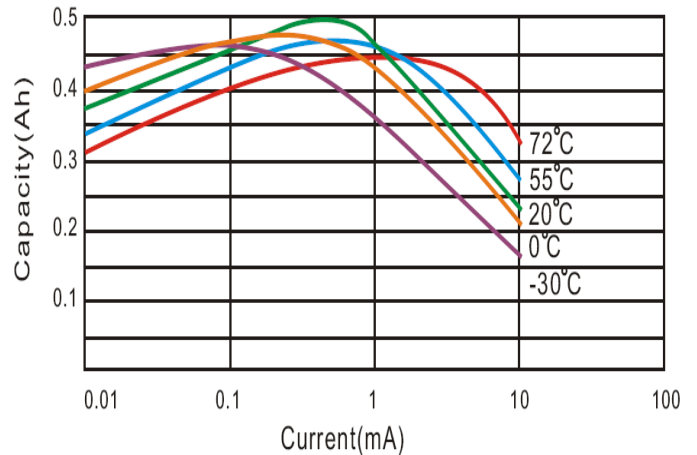

■ Voltage VS. Temperature

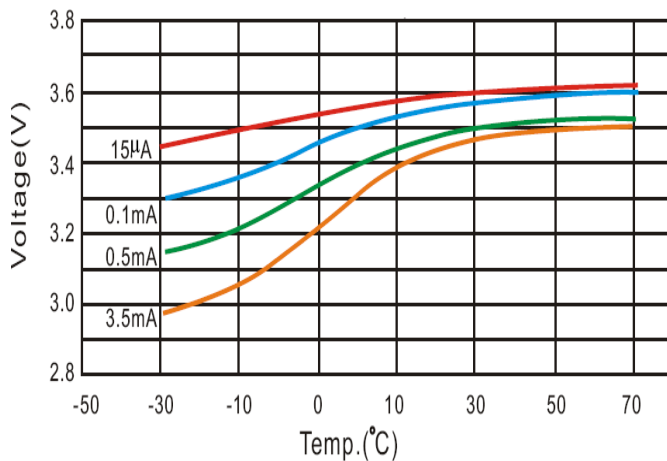

■ Important Notes:

Do not short or charge the battery.
 Over-discharging, crushing, incinerating, and disassembling the battery are prohibited.
 Do not heat/use the battery beyond the permitted temperature range.