

TELONG ENERGY TECHNOLOGY CO., LTD.

Anjia Industrial Zone, HuanGuan South Road, GuanLan Town, ShenZhen City, GuangDong Province, China
TEL:+86-755-29052355 FAX:+86-755-27981742 E-mail:telongbattery@sztlg.com <http://www.sztlg.com>

ML123A Rechargeable Lithium-manganese Battery

TECHNICAL DATA

ITEM	CHARACTERISTICS	NOTES
Nominal voltage	3.0 V	No load
Nominal capacity	500 mAh	Under normal temperature, discharging at the rate of 0.2 C to 2.0V.
Charge and discharge current	0.2 C	Standard current
	0.5 C	Biggest current
Cycle life	500~800	Discharge current 0.2 C, in the case of 10%-20% discharge depth, can be recycled 500-800 times , Full be filled with to put, can be recycled 300 times.
Charging voltage	3.1 ~3.3 V	Standard current charging
Open circuit voltage	≥3.0 V	No load
Storage temperature	20~25℃	RH: 50±10%
Standard weight	14.0 g	Each cell
Dimension of shape	Diameter: 17.0(±0.5) mm Height: 34.0(-0.8) mm	Using the vernier caliper of the accuracy.
Self-discharge rate	≤ 5%	Stored for 12 months under the condition of normal temperature and humidity.
Appearance	Appearance is level, smooth and clear, no distortion, no rust	Eyeballing
Vibration test	Put the charger on the vibrator and use the 10-15 times per minute frequency to vibrate the charger for one hour, the charger performance is stable.	The charger performance is stable.
Falling test	Put the charger from 2m height to the floor by vertical direction and free direction, after 5 times, the charger performance is stable.	The charger performance is stable.

TECHNICAL CHARACTERISTICS

1. The methods of testing

A: environment and temperature: 20~25°C; the environment humidity of 50±10%.

B: Charge at the rate of the constant current 0.2 C to 3.25V, changing it into the constant current for 60 minutes, keeping it still for 10 minutes; Discharge at the rate of the constant current 0.2 C to 2.0V.

2. Caution

- 2.1 Install and use the cells right, avoid short circuit and shun reversing anode and cathode.
- 2.2 Check the cell polarity and the equipment including its conjunction before installing, ensuring the cleanness and conductivity, the equipment should not cause short circuit.
- 2.3 Do not mix the new cells with the old ones, and not mix the different volume, brand, grade, type cells lest affecting characteristics and the possibility of leaking.
- 2.4 The cells should not be heated and collided after being used lest explosion, damage and liquid-leaking.
- 2.5 Don't use too high current to charge and discharge when using the cells, do not overcharge and discharge lest affecting the cycle life of the cells.
- 2.6 To avoid danger, don't put the cells into the fire disassemble the cells.
- 2.7 Taking care of the micro-cells well lest the infants swallow.
- 2.8 Pay attention to the storage expiry of the cells.

3. 【3.0V ML Rechargeable Battery Structure】

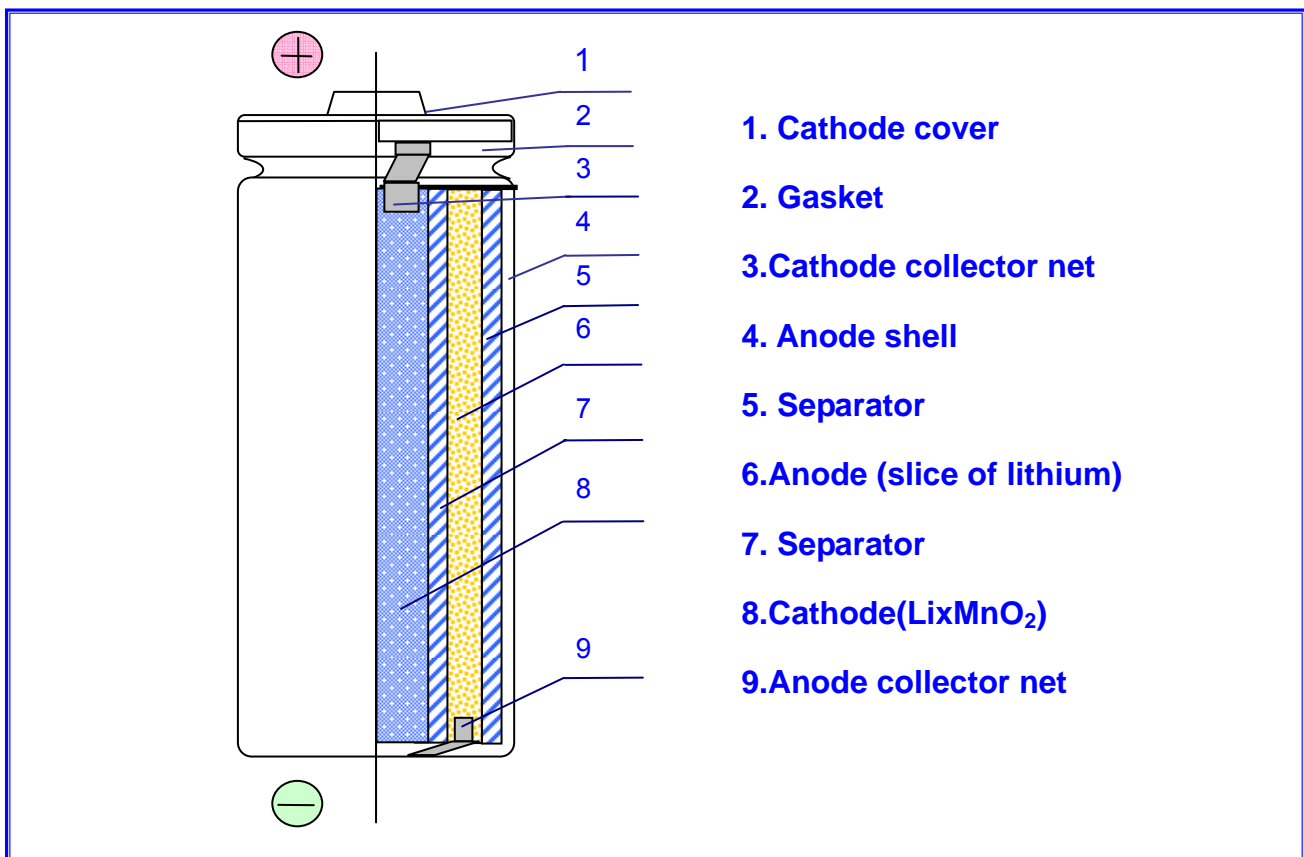

4. 【APPEARANCE】

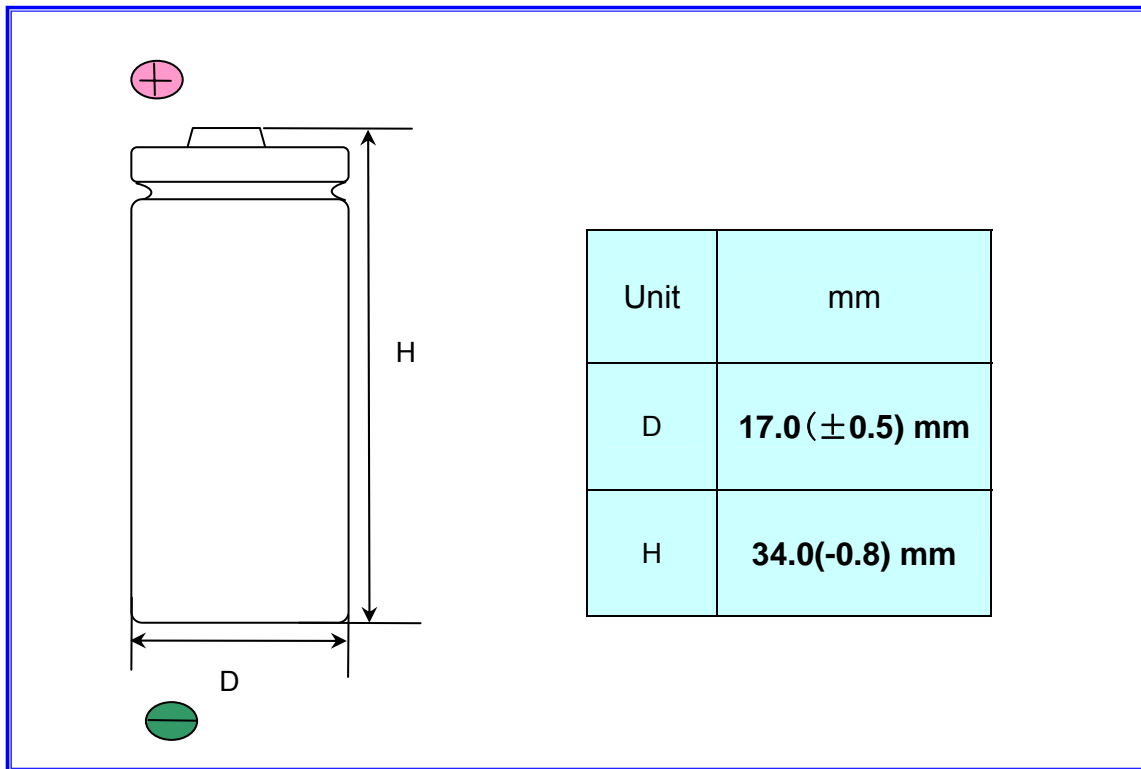

5. 【SPECIFICATIONS】

Nominal Capacity		500 mAh
Nominal Voltage		3.0 V
Standard Charge/Discharge Current		0.2 C
Charge/Discharge Cycle Characteristics	Discharging Depth of 10%	800 times
	Discharging Depth of 20%	500 times
Temperature Range		-20~60 °C
Weight		14.0 g
Dimensions	Diameter	17.0_{±0.5} mm
	Height	34.0_{-0.8} mm