

TELONG ENERGY TECHNOLOGY CO., LTD.

Anjia Industrial Zone, HuanGuan South Road, GuanLan Town, ShenZhen City, GuangDong Province, China
 TEL:+86-755-29052355 FAX:+86-755-27981742 E-mail:telongbattery@sztlg.com <http://www.sztlg.com>

SR1130 Silver Oxide Button Cell

TECHNICAL DATA

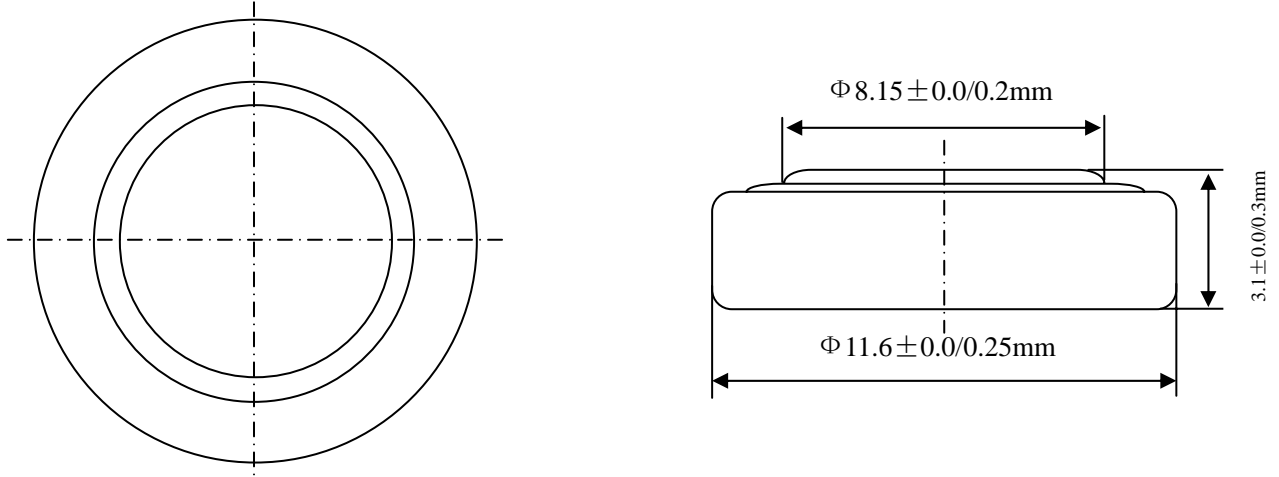

Model	Voltage	Capacity	Diameter	Height	ICE	JST	Eveready	Weight
389	1.55V	67mAh	11.6mm	3.1mm	SR54	SR1130SW	389	1.11g

TECHNICAL CHARACTERISTICS

Standar Discharge Curve:

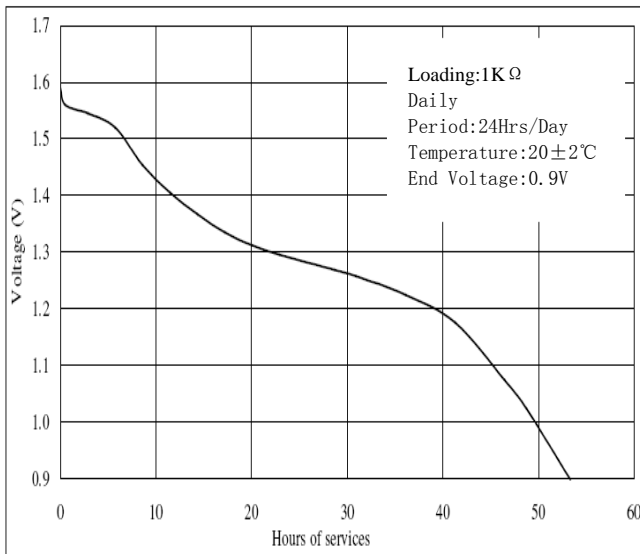

Temperature Characteristic:

